

# Guide to Genuine Yamaha Doors/Handholds and Rhino Occupant Protection

Keep this guide with your owner's manual

## Introduction

You can have genuine Yamaha doors and additional passenger handholds installed for free. This guide can help you understand how these doors/handholds fit into an overall approach to occupant safety.

### Know Your Vehicle

Keep in mind that the Rhino has higher ground clearance and other features to handle rugged terrain, and, as a result, can overturn in situations where some vehicles may not. This would include vehicles made primarily for pavement, roads, improved paths, or grounds-keeping. If you do not use care in maneuvering the Rhino, you can cause it to roll over even on flat, open areas.

Doing things with a Rhino that some people do for thrills in other vehicles (such as sideways sliding, skidding, fishtailing, or donuts) have led to side rollovers. These rollovers can result in crushed limbs and other serious injuries or death to drivers or passengers.

As the owner/operator, it is your responsibility to protect yourself and your passenger from accidents, including rollovers. The Rhino has many features, including a protective structure and seatbelts, to help protect occupants, but the best way to avoid injuries is to avoid accidents. There is a risk of injury or death in any accident, even with these safety features.

<b>CONTENTS</b>
– Introduction
– Overview of Occupant Protection
– Head to Toe Safety Checklist
– Driver and Passenger Requirements

## Overview of Occupant Protection

The Rhino comes with a variety of features to help reduce the risk of driver and passenger injury. These features work together, and when properly used, these features will help protect the occupants in the event of an accident. If these features are not used properly, they can cause injury.

If you install aftermarket products or have your vehicle modified, you may put yourself and others at greater risk of serious injury or death. You are responsible for any such changes to the vehicle.

### 1. Protective Structure

The vehicle cage/frame provides a protective structure that helps limit intrusions by branches or other objects and may reduce your risk of injury in accidents. The protective structure will not protect occupants in all rollovers or accidents.

Body parts outside of vehicle can be struck by passing objects or crushed during vehicle rollover. Do not put your hands or feet outside of the vehicle for any reason. Do not hold onto the door, cage/frame or hip restraint bar. Wear your seatbelt and helmet.

If you think or feel that the vehicle may tip or roll, do not put your hands or feet outside the vehicle for any reason. You will not be able to stop the vehicle from tipping over using your body. Any part of your body (arms, legs, and head) outside of the vehicle can be crushed by the vehicle cage/frame.

### 2. Seat belts

Seat belts should be worn by both driver and passenger. Driver must be sure that the passenger is belted before driving.

- Be sure the seat belt is not twisted, is close-fitting across the hips and chest, and is latched securely.
- Do not wear the lap belt across the abdomen or stomach.
- Do not the shoulder belt behind the back. put
- Failure to use seat belts properly may lead to an increased likelihood and severity of injury.

An unbelted occupant may strike the interior of the vehicle, the protective structure, or other objects in an accident or during operation. You may also fall completely out or be partially ejected from the vehicle, which may

lead to being crushed between the ground and the vehicle. Wearing the seat belt helps you remain in the vehicle – the doors and handholds are not a substitute for using a seat belt.

### 3. Doors



Now available at your dealership for free.

The doors are designed to reduce the likelihood that you will stick your leg out to stop the vehicle from tipping over or for any other reason in a rollover. The doors may also reduce intrusion of objects into the occupant area. Make sure the door is securely latched before operation. Do not place your arm or hand on the door during operation. Your hand or arm may be struck by objects or crushed against outside objects or the ground during a rollover.

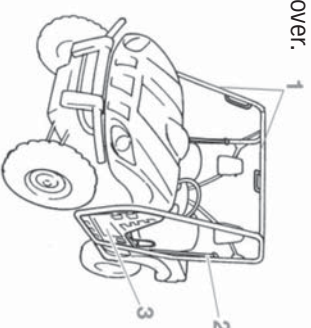

## 4. Passenger Handholds



Additional passenger handholds are now available at your dealership for free.

Handholds are provided to grip during operation to maintain proper position and balance. Holding onto the handholds helps to reduce the likelihood that the passenger puts a hand outside the vehicle if the vehicle begins to tip. There are two handholds on the protective structure. Two new handholds are available on the passenger's left side, for the right and left hands.

The driver should make sure the passenger is holding onto the handholds with both hands before operating the vehicle.

### 5. Seat & Hip Restraints

The seat and hip restraints are designed to help keep you in the vehicle. Do not hold onto the hip restraint bar when the vehicle is moving. Your hand or arm may be struck by objects or crushed against outside objects or the ground during a rollover.

## 6. Floorboard

The floorboard allows you to brace your feet, which helps you keep your body in the vehicle in the event of an accident or rollover. Keep your feet on the floorboard during operation.

### 7. Steering Wheel

When driving, keep both hands on the steering wheel.

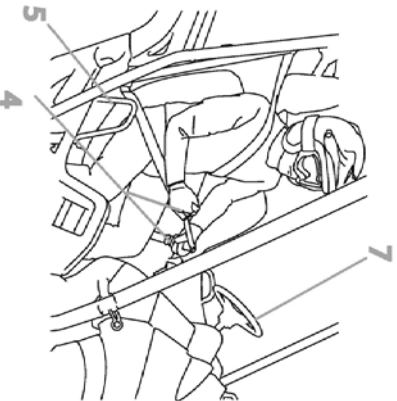

## Head to Toe Safety Checklist

- ✓ **Head**      Helmet and eye protection.
- ✓ **Body**      Seatbelt and protective clothing.
- ✓ **Hands**      Inside vehicle and holding the handholds or steering wheel.
- ✓ **Feet**      On floorboard, ready to brace, and door closed.

# Driver and Passenger Requirements

## Driver Requirements

- This vehicle is intended for use only by an operator 16 or older with a valid motor vehicle license.



- The driver must be able to place both feet flat on the floorboard while seated upright with back against the seat back.
- Do not drive after using drugs or alcohol.
- Remove the ignition key when the vehicle is not in use to prevent unauthorized use of the machine.

## Passenger Requirements

Your Rhino is designed for the operator and one passenger. Carrying passengers improperly can lead to serious injury or death. As the operator, you are responsible for your passenger.

- Your passenger must be able to place both feet on the floorboard while seated upright with his/her back against the seat back.
- Allow only one passenger on the vehicle in the passenger seat. Do not carry any other passengers. Do not carry passengers in the cargo bed.
- Do not allow someone to ride as a passenger who has been using drugs or alcohol.

### Parents:

Many provinces have implemented new motor vehicle licensing requirements for young drivers. These requirements are in response to the disproportionately high rate of crashes involving youthful drivers. As with automobiles, to promote safe driving behaviors, you should supervise younger drivers and consider setting rules and putting limits on how, when, and where the Rhino can be used.